

REALIST

STAIR TREAD PROFILES

REVERE

Revere Flooring is proud to present our exclusive line of stair tread profiles which can be used in coordination with the Realist collection. All stair tread profiles use film coordinating with the LVP flooring to display an almost identical match.

STAIR TREAD ROUND NOSE TREAD-12

30 Pc Min
Per Color/
Profile

Dimensions: 47" x 12" x 1.729" outside (1.375" inside)



STAIR TREAD SQUARE NOSE TREAD-30

30 Pc Min
Per Color/
Profile

Dimensions: 47" x 11.5" x 1.729" outside (1.375" inside)



REALIST

LANDING PROFILES

REVERE

Realist landing profiles are designed to coordinate seamlessly with Realist stair tread profiles, ensuring a consistent, finished look across every step. These matching components allow the landing profile to complement the tread design for a cohesive installation.

FLUSH LANDING PROFILE ROUND V-FSN-50

30 Pc Min
Per Color/
Profile

Dimensions: 5" x 1.6"

Designed for coordinated use with Realist Stair Treads.



FLUSH LANDING PROFILE SQUARE V-FSN-60

30 Pc Min
Per Color/
Profile

Dimensions: 5" x 1.6"

Designed for coordinated use with Realist Stair Treads.



REALIST

STAIR TREAD INSTALLATION INSTRUCTIONS

REVERE

TOOLS NEEDED



BEFORE YOU BEGIN

Remove any carpet, staples, etc. from your stairs.

STEP 1

Carefully measure width and depth of the step. Then cut (decor up) your tread to size and dry-fit to ensure a proper fit.

(Measure and cut each stair/tread separately as they may be different. Steps may not all be square.)

Pro Tip: Use painter's tape on the cut line before cutting to prevent chatter at the cut edge of your tread.

STEP 2

Apply roughly a 1/4" bead of **urethane construction adhesive** about 1" from the edges and in a serpentine pattern with approx. 1.5" of space between each line. **Add a generous amount of adhesive into the bullnose as well.**



STEP 3

Carefully position treads on step approx. 1" from the riser and slide into place. Apply firm pressure to tread surface and follow adhesive manufacturers application guidelines.

Remove any excess adhesive immediately! Allow sufficient dry time (as recommended by adhesive manufacturer) before using your steps.

Pro Tip: We recommend securing the back end with finishing nails until the construction adhesive cures.

IF YOUR EXISTING STAIR TREAD HAS A SQUARE END (NO BULLNOSE) FOLLOW THE PLACEMENT PROCEDURE BELOW



V-T-14 VINYL T-MOLDING

Used to fill the gap between two floors of equal height.

Used with floors ranging from 2-6mm in height.

Dimension: 1.77"w x 0.28"h

Surface: Wear resistant

Core Material: Rigid PVC

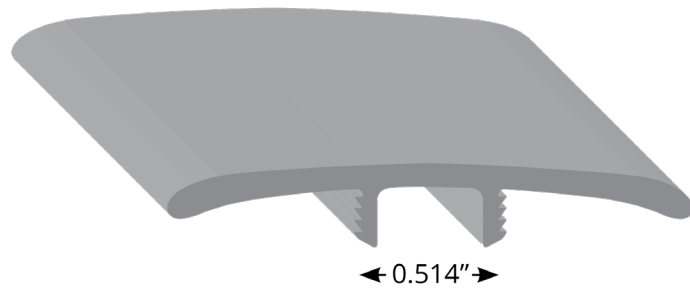

1

Install the flooring leaving a 1-1/8" gap between the two floors for the t-molding installation.

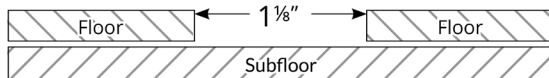

2

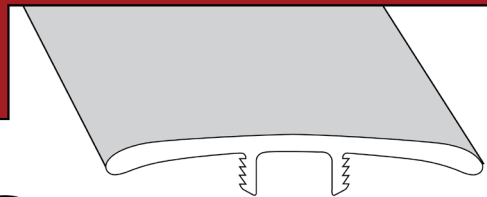

Measure and trim to fit.

3

Center the track between the flooring leaving a 1/4" spacing between the track and floor planks. Screw track to subfloor using included screws (or glue down with construction adhesive).

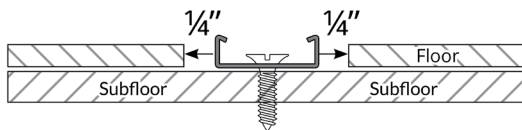

4

Starting at one end, press the molding into the track inching along the length of the molding. *It will NOT snap in all at once. You may also use a rubber mallet.*

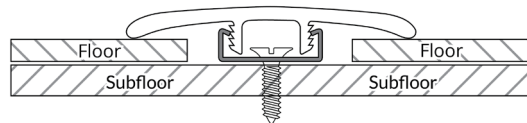

V-EC-14 VINYL END CAP

Used to fill the gap between the floor and carpet, hearths or against sliding doors.

Used with floors ranging from 2-6mm in height.

Dimension: 1.5"w x 0.25"h

Surface: Wear resistant

Core Material: Rigid PVC

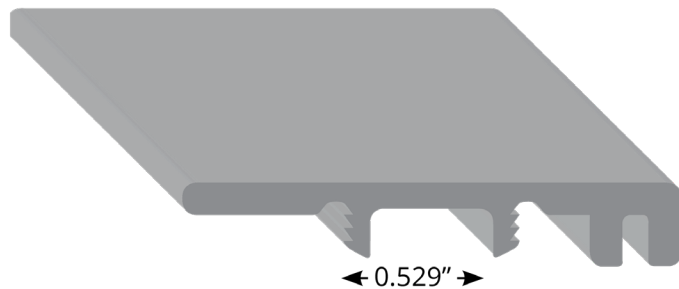

1

Install the flooring leaving a 1-1/4" gap between the two floors for the end cap installation.

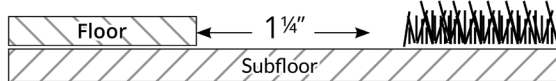

2

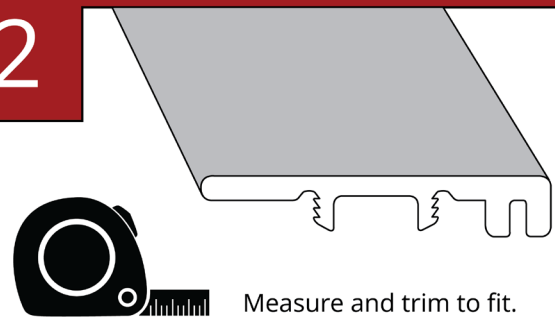

3

Center the track between the flooring leaving a 1/4" spacing between the track and floor planks. Screw track to subfloor using included screws (or glue down with construction adhesive).

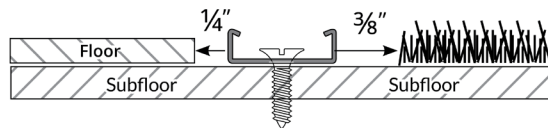

4

Starting at one end, press the molding into the track inching along the length of the molding. *It will NOT snap in all at once. You may also use a rubber mallet.*

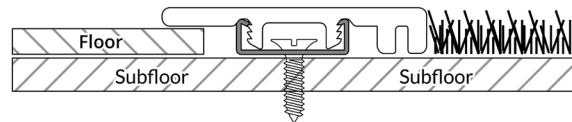

V-SR-14 VINYL REDUCER

Used to fill the gap between two floors of unequal height.

Used with floors ranging from 2-6mm in height.

Dimension: 1.77"w x 0.345"h

Surface: Wear resistant

Core Material: Rigid PVC

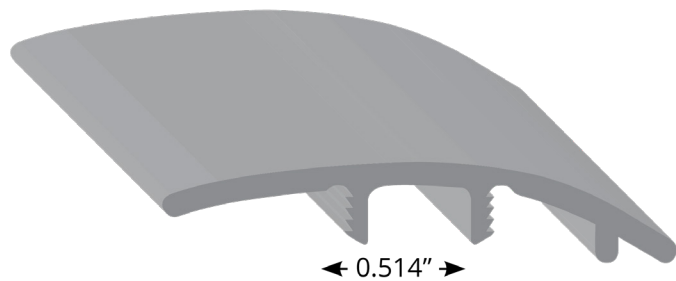

1

Install the flooring leaving a 1-1/8" gap between the two floor surfaces for the surface reducer installation.

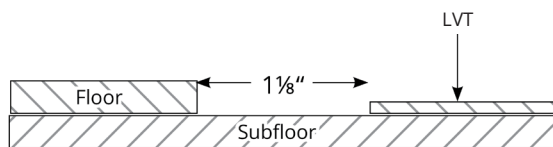

2

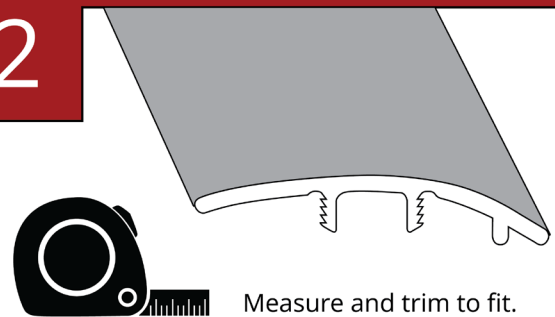

3

Center the track between the flooring leaving a 1/4" spacing between the track and floor planks. Screw track to subfloor using included screws (or glue down with construction adhesive).

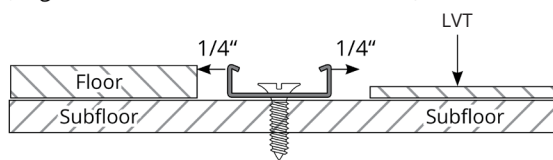

4

Starting at one end, press the molding into the track inching along the length of the molding. *It will NOT snap in all at once. You may also use a rubber mallet.*

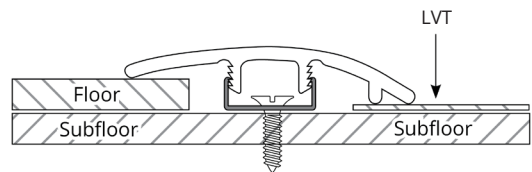

V-FSN-15 VINYL FLUSH STAIR NOSE ROUND

Used to finish the end of a step.

Dimension: 2.75"w x 0.84"h
Surface: Wear resistant
Core Material: Rigid PVC

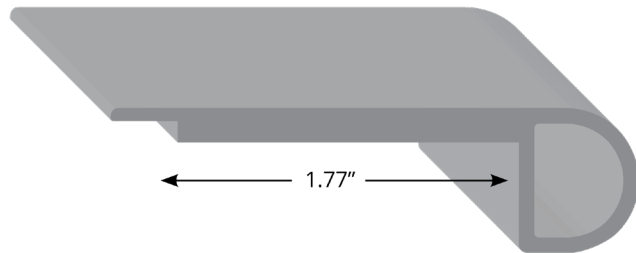

1

Measure and trim to fit.

2

Apply a generous bead of construction adhesive along the underside of the stair nose.

3

Carefully roll the stair nose into place against the front of the step, making sure the transition is in place. Once the transition is in its desired position, press down firmly over the entire stair nose, making certain the transition is in place and tight against the riser. For added security, use finishing nails.

Let the adhesive cure according to directions.

V-SN-06 VINYL OVERLAP STAIR NOSE ROUND

Used to finish the end of a step.

Dimension: 2.23"w x 1.034"h

Surface: Wear resistant

Core Material: Rigid PVC

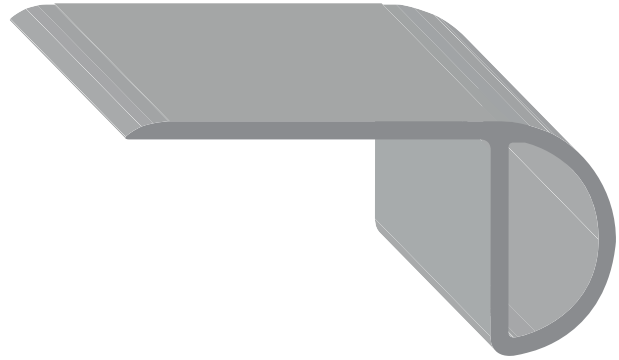

1

Measure and trim to fit.

2

Apply a generous bead of construction adhesive along the underside of the stair nose.

3

Carefully roll the stair nose against the front of the step, making sure the transition is in place. Once in its desired position, press down firmly over the entire stair nose.

Let the adhesive cure according to directions.

Riser

4

For added security, use finishing nails.

Floor

Subfloor

Riser

V-SN-01 VINYL OVERLAP STAIR NOSE SQUARE

Used to finish the end of a step.

Dimension: 2.0"w x 1.15"h

Surface: Wear resistant

Core Material: Rigid PVC

